

LCT
(Machine Code: B511)

1. INSTALLATION

For a details about installing the LCT B511, please refer to the instructions you received with the unit or “1. Installation” in the main machine service manual.



2. PREVENTIVE MAINTENANCE

For more details about preventive maintenance for the LCT B511, please refer to Section “2. Preventive Maintenance” in the main machine service manual.

3. REPLACEMENT AND ADJUSTMENT

3.1 FRONT DOOR AND COVERS

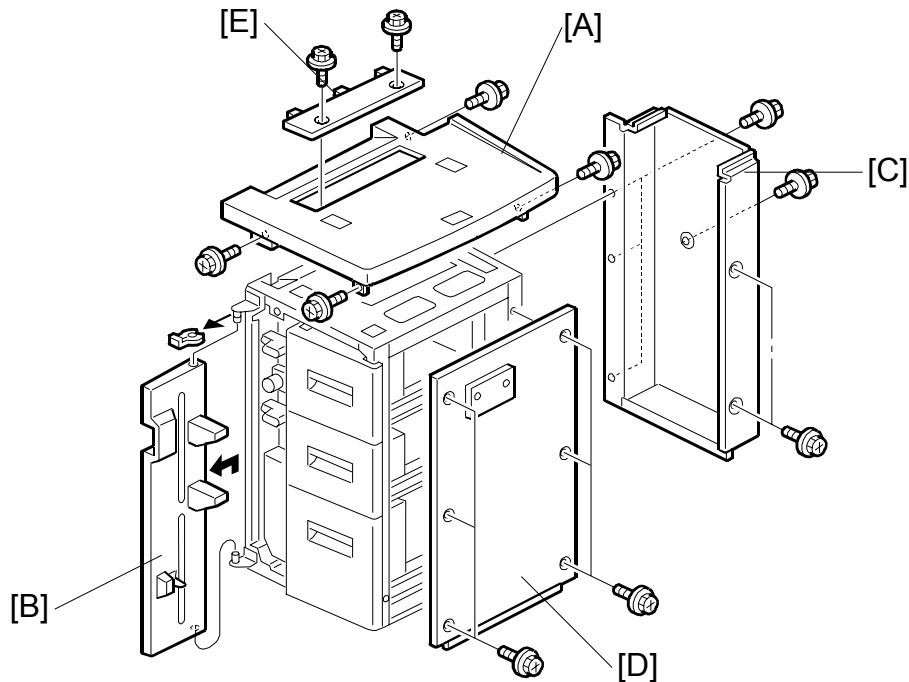

B511R101.WMF

1. Remove the top cover [A] (⚙ x 4).
2. Remove the front door [B] (⚙ x 1).
NOTE: While lifting the top cover, remove the snap ring and front door.
3. Remove the rear cover [C] (⚙ x 6).
4. Remove the right cover [D] (⚙ x 6).
5. Remove the paper slot cover [E] (⚙ x 2).

3.2 INNER COVER, PAPER FEED UNIT

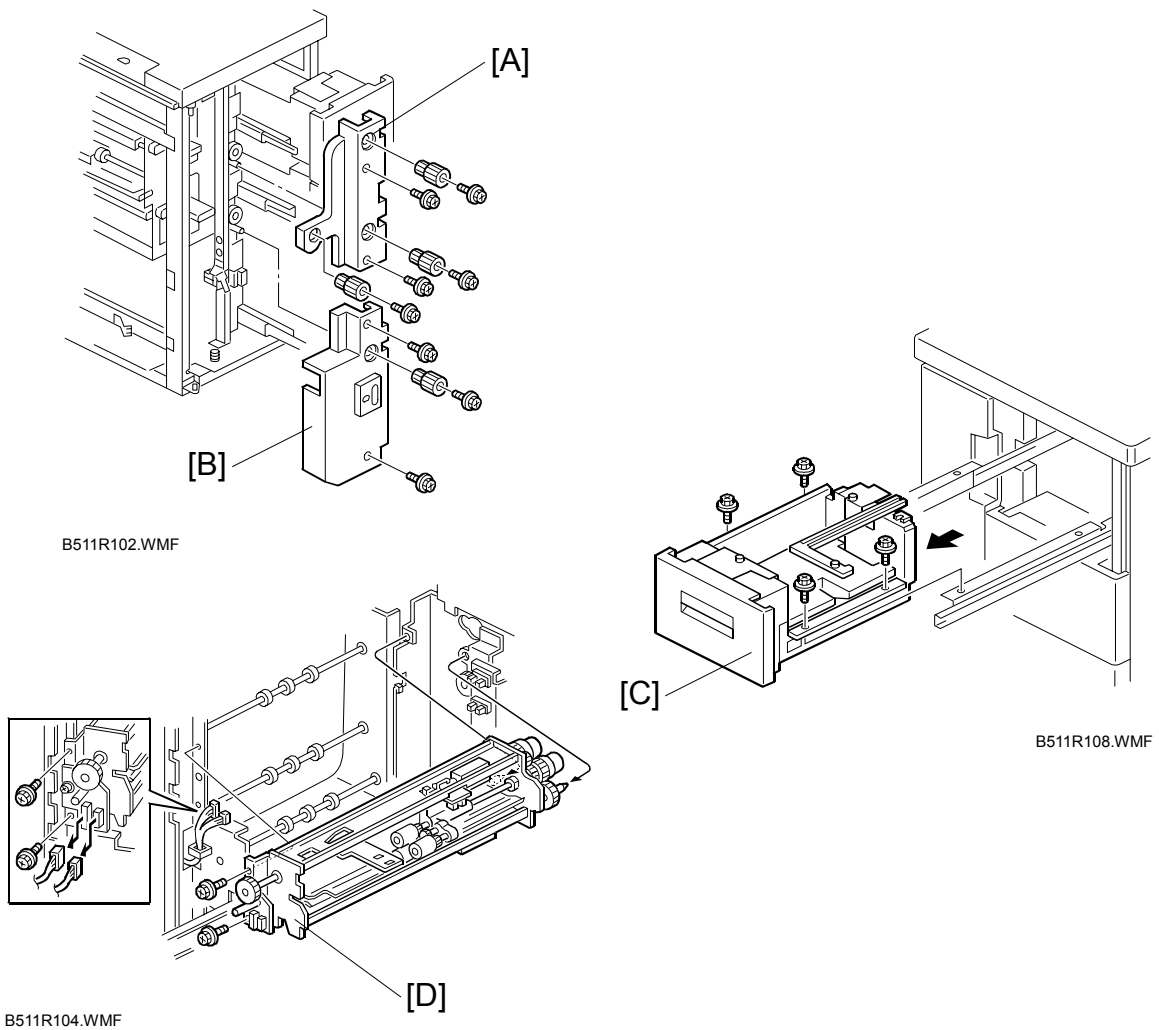

1. Open the front door and remove the upper inner cover [A] (⚙ x 5, knobs x 3).
2. Open the front door and remove the lower inner cover [B] (⚙ x 3, knob x 1).
3. Pull out the tray [C] and remove it (⚙ x 4).
4. Remove the right cover (⚙ x 6). (☞3.1)
5. Remove the paper feed unit [D] (⚙ x 2, ⚙ x 2).

3.3 PAPER FEED ROLLER

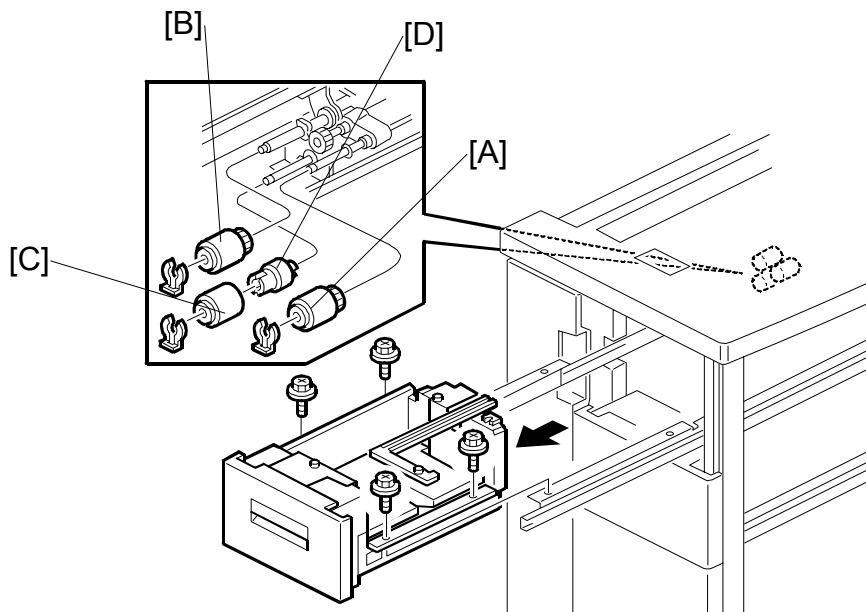

B511R103.WMF

1. Remove the right cover (☛3.1).
2. Remove the paper trays. (☛3.2).
3. Remove the pick-up roller [A] (☞ x 1).
4. Remove the feed roller [B] (☞ x 1).
5. Remove the separation roller [C] from the torque limiter [D] (☞ x 1).

NOTE: 1) The LCT pick-up and separation rollers are the same as pick-up and separation rollers of the main machine. These rollers are interchangeable.

2) The feed rollers of the LCT and main machine are different because they are designed to rotate in opposite directions. The feed rollers of the LCT and main machine are not interchangeable.

3) Do not touch the surface of the rollers with bare hands.

6. Reset the counters for the new rollers with SP7816 005~007 (Print Counter Reset – Paper Trays)

3.4 LCT MOTOR

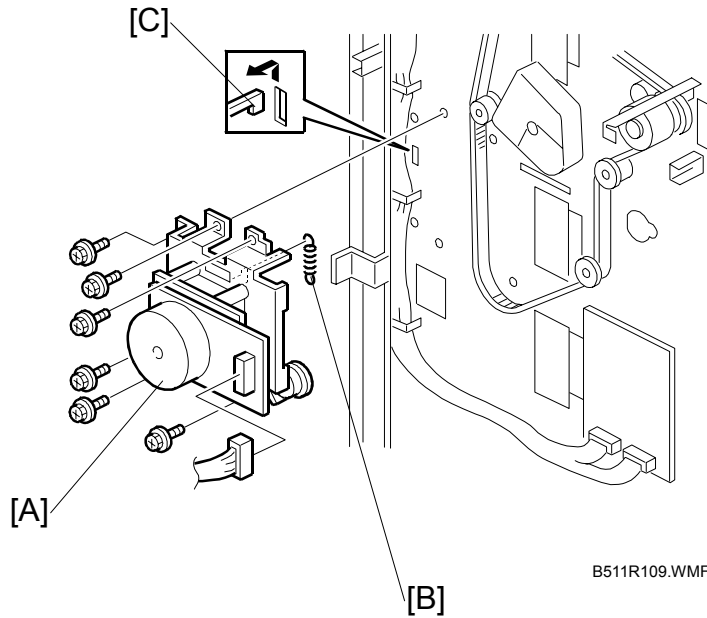

1. Remove the rear cover. (☛3.1)
2. Remove the motor bracket with the LCT motor [A] (☛ x 1, harness clamps x 3,  x 6, spring x 1).
NOTE: The spring [B] is behind the motor. Raise the motor slightly to release the hook [C].

3.5 MAIN DRIVE BELT

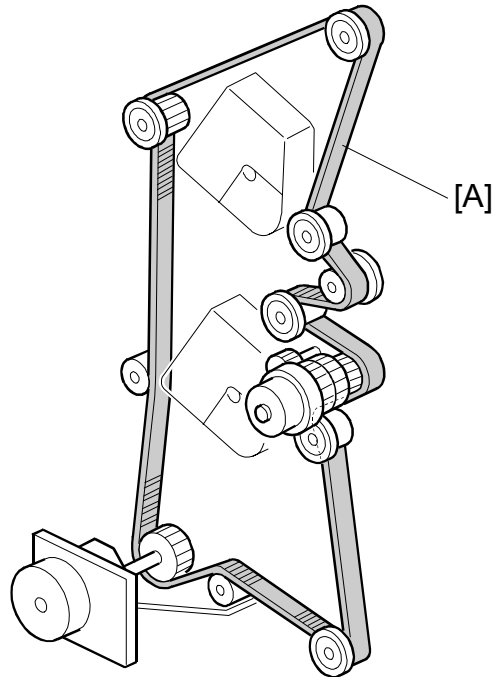

B511R107.WMF

1. Remove the rear cover. (☛3.1).
2. Remove the LCT motor (⚙ x 6). (☛3.4)
3. Remove the main drive belt.
4. Mount the main drive belt [A] as shown in the illustration.

NOTE: If a pulley or gear is removed in the belt path, be sure to re-attach it correctly.

3.6 EXIT SENSOR

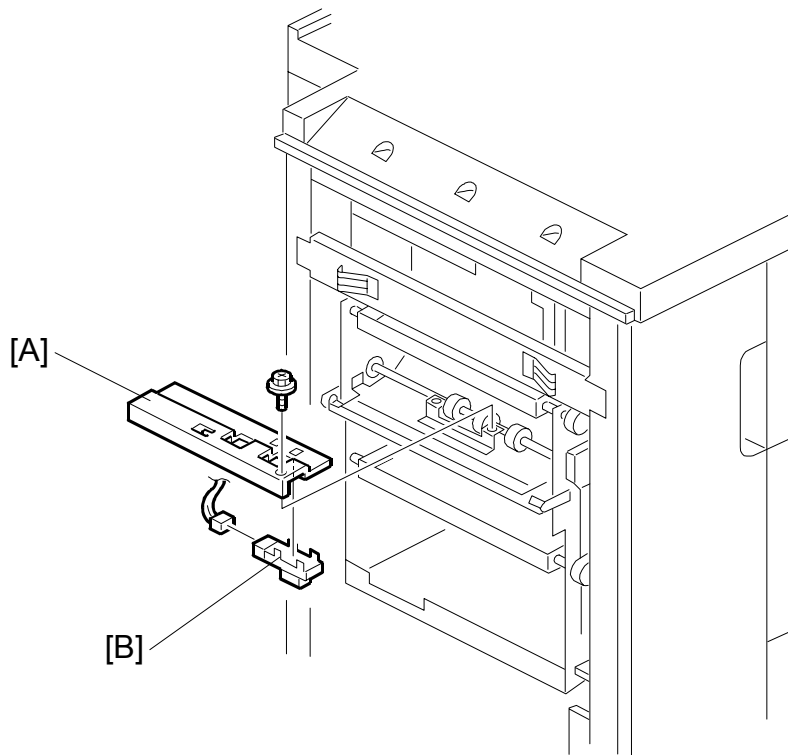

B511R105.WMF

1. Disconnect the LCT from the copier.
2. Remove the bracket [A] (🔩 x 1).
3. Remove the exit sensor [B] (🔌 x 1).

3.7 PAPER HEIGHT SENSOR, PAPER SIZE SWITCH

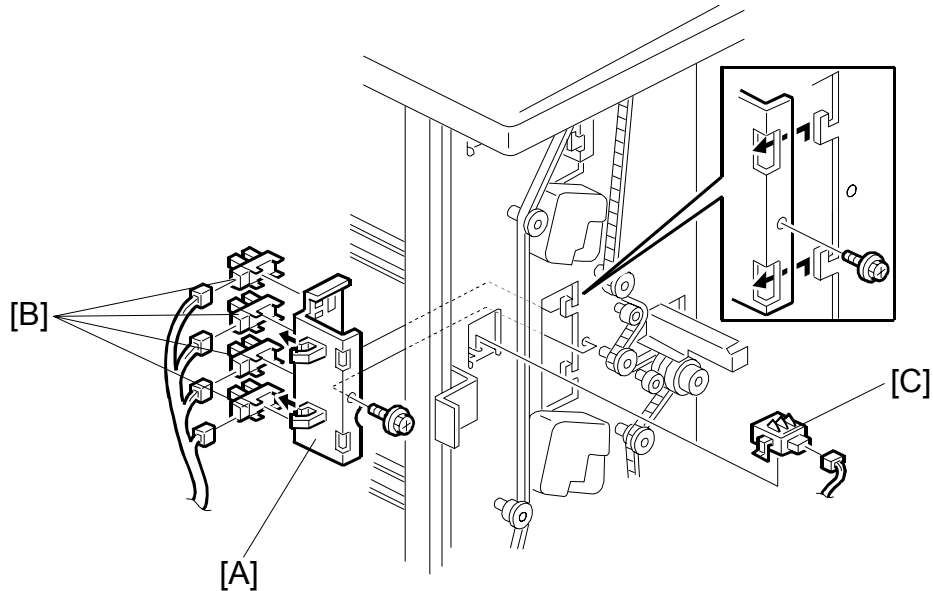

B511R106.WMF

1. Rear cover. (☛3.1)
2. Right cover. (☛3.1)
3. Paper height sensor bracket [A] (☛ x 1, ☛ x 4).
4. Paper height sensors [B] (hooks x 4 each)
5. Paper size switch [C] (☛ x 1).

3.8 SIDE REGISTRATION ADJUSTMENT

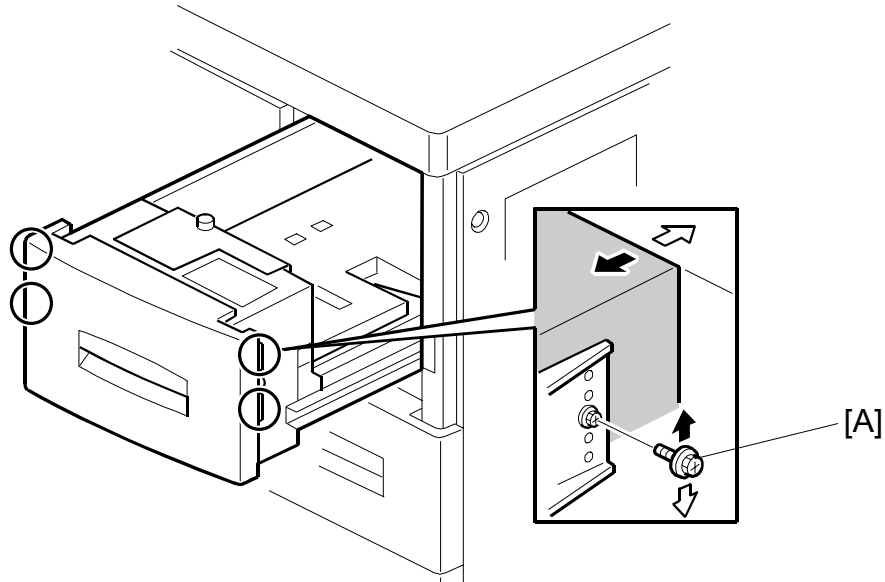

B511R112.WMF

Normally the side registration of the image can be adjusted with SP1002 004~006 (Side-to-Side Registration – Tray 4, 5, 6). When the punch hole positions are not aligned from a particular feed station, adjust the side registration by changing the tray cover position for the tray, as described below. Then adjust the side registration of the image with the SP1002.

1. Pull out the tray.
2. Change the screw positions [A] at both the right and left sides as shown.

NOTE: Adjustment range: 0 ± 2.0 mm adjustment step: 1.0 mm/step

4. TROUBLESHOOTING

For details about LCT-related SC codes, please refer to “4. Troubleshooting” in the main machine service manual.

5. SERVICE TABLES

For details about LCT-related SP codes, please refer to “5. Service Tables” in the main machine service manual.

6. DETAILED DESCRIPTIONS

6.1 PAPER FEED

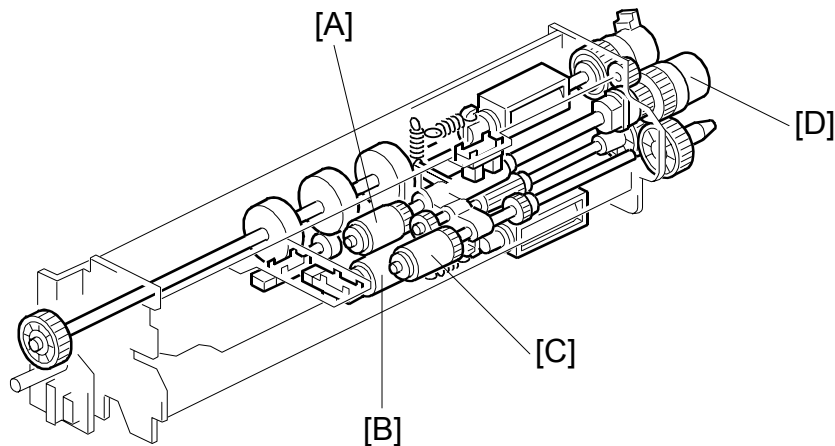

B511D113.WMF

This LCT has three paper tray feed stations.

The upper and middle trays can each hold 1,000 sheets of paper. The lower tray can hold 2,550 sheets of paper.

All feed stations use an FRR paper feed system (paper feed roller [A], separation roller [B], pick-up roller [C]), and those rollers are driven by the LCT motor via the paper feed clutch [D].

6.2 PICK-UP AND FEED

6.2.1 OVERVIEW

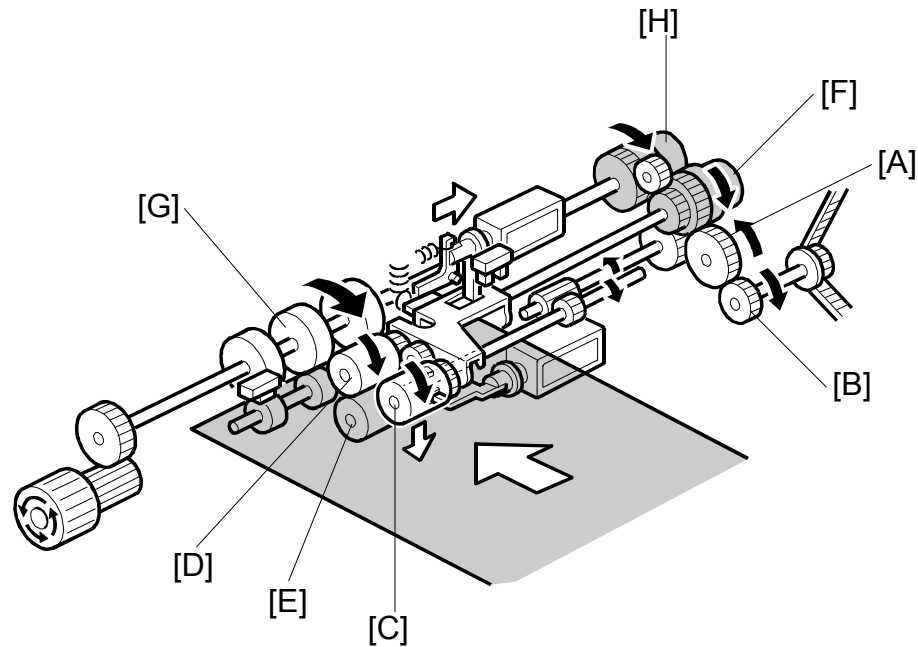

B511D105.WMF

Drive from the LCT motor is transmitted to the gear [A] in the paper feed unit via the timing belt [B].

Then the gear [A] transmits the drive to the pick-up [C], paper feed [D], and separation [E] rollers via gears and the paper feed clutch [F].

The gear [A] also transmits the drive to the grip roller [G] via gears and the grip roller clutch [H].

6.2.2 PICK-UP AND FEED

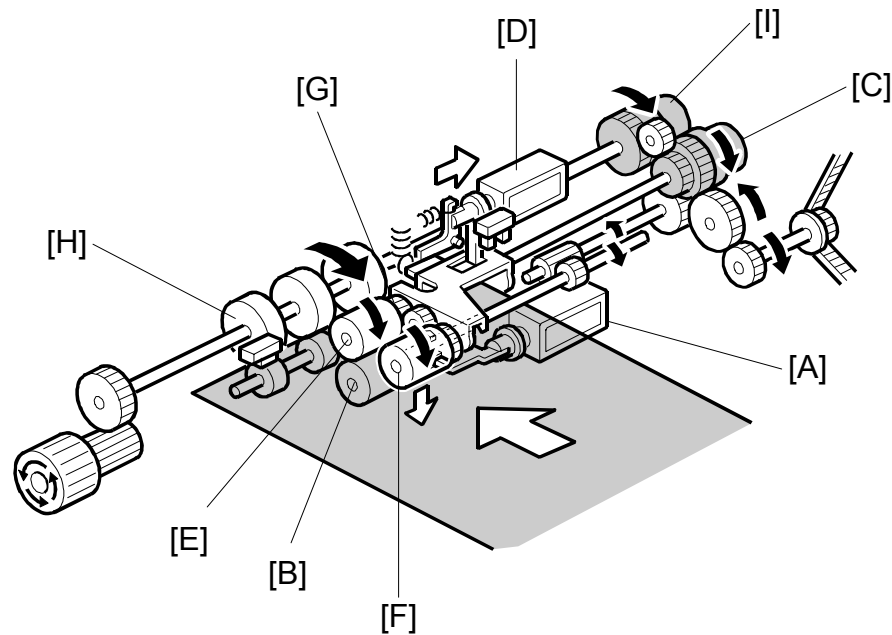

B511D105.WMF

When a paper feed station is not selected, its separation roller solenoid [A] is deactivated and the separation roller [B] can turn freely.

When the paper feed station is selected and the Start key is pressed, the feed clutch [C], separation roller solenoid [A], and pick-up solenoid [D] turn on.

When the feed clutch [C] actuates, it drives the feed roller [E], and turns the pick-up roller [F] because it is linked to the feed roller by an idle gear [G].

When the separation roller solenoid [A] turns on, the separation roller [B] contacts the paper feed roller [E] and turns with the feed roller, unless more than one sheet of paper is fed. The three trays of the LCT unit use the standard FRR mechanism.

☛ **CT** Handling Paper > Paper Feed Methods > **Forward and Reverse Roller (FRR)**

When the pick-up solenoid [D] actuates, the pick-up roller [F] lowers until it contacts the top sheet of the paper stack and then sends it to the paper feed and separation roller.

When the paper feed sensor [H] detects the leading edge of the paper, the pick-up solenoid de-actuates and lifts the pick-up roller [F], and the grip roller clutch [I] actuates and feeds the paper out of the tray.

6.2.3 SEPARATION ROLLER RELEASE

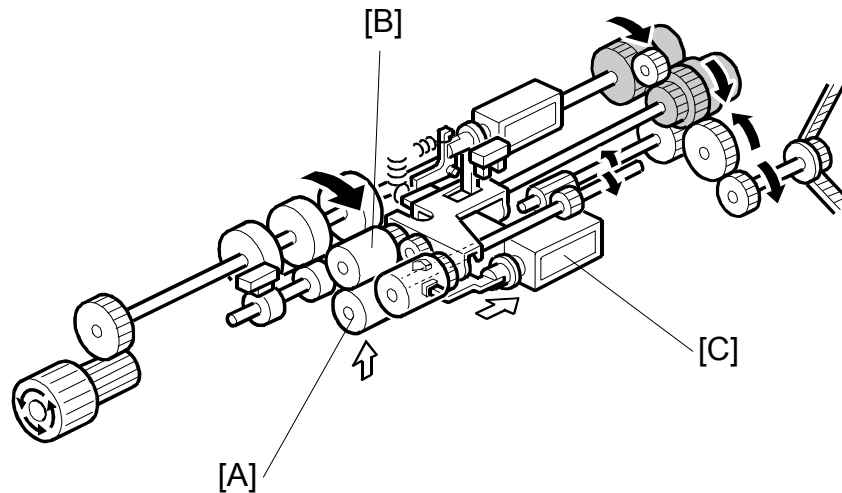

B511D104.WMF

The separation roller [A] is normally away from the feed roller [B]. When the paper feed station is selected, the separation roller solenoid [C] contacts the separation roller with the feed roller as explained on the previous two pages.

This contact/release mechanism has the following three advantages:

1. When the LCT motor turns on, all the separation rollers in the three feed stations rotate. If the separation roller is away from the feed roller, it reduces the load on the paper feed motor and drive mechanism, and it also reduces wear to the rubber surface of the separation roller caused by friction between the separation roller and the feed roller.
2. After paper feed is completed, paper sometimes remains between the feed and separation rollers. If the feed tray is removed at this time, this paper might be torn. When the separation roller is away from the feed roller, the remaining paper can be removed from between the rollers.
3. When paper misfeeds occur around this area, the user can easily pull out the jammed paper between the feed and the separation rollers if the separation roller is away from the feed roller.

After paper feed, the paper feed clutch turns off, but the LCT motor still turns the separation roller [A] in reverse. The separation roller, still contacting the feed roller, turns the feed roller in reverse for 100 ms. Then the separation solenoid turns off.

6.3 PAPER LIFT

6.3.1 TRAY DETECTION

When a tray is set in the machine, the tray detection method used depends on the tray:

- The upper tray and middle tray are detected when any one of the paper size switch signals is low.
- The lower tray is detected when the switch 1 signal of the paper size switch is low.

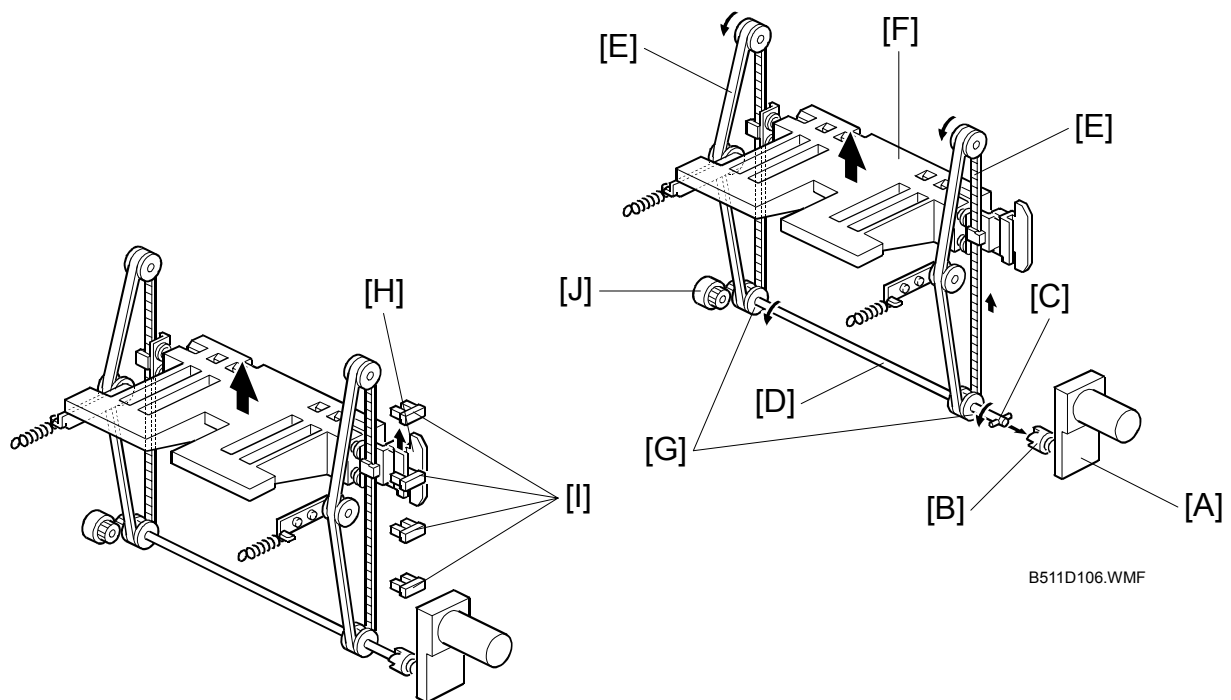

B511D109.WMF

B511D106.WMF

6.3.2 LIFT MECHANISM

When the machine detects that the paper tray is set in the machine, the tray lift motor [A] rotates and the coupling gear [B] on the tray lift motor engages the pin [C] of the lift drive shaft [D]. The tray drive belts [E] are connected to the tray bottom plate [F] and are driven by the tray lift motor via the lift drive shaft [D] and tray drive pulleys [G]. When the lift motor turns counterclockwise, the tray bottom plate [F] moves up. The tray goes up until the top of the paper stack pushes up the pick-up roller and the lift sensor in the feed unit is de-activated.

When the actuator [H] on the rear end of the bottom plate activates the paper height sensors [I], the remaining paper capacity is detected. (●6.5)

When pulling out the tray, the coupling gear [B] separates from the pin [C], so that the tray bottom plate moves downward. In the bottom tray, the damper [J] lets the tray bottom plate drop slowly.

6.3.3 LIFT SENSOR

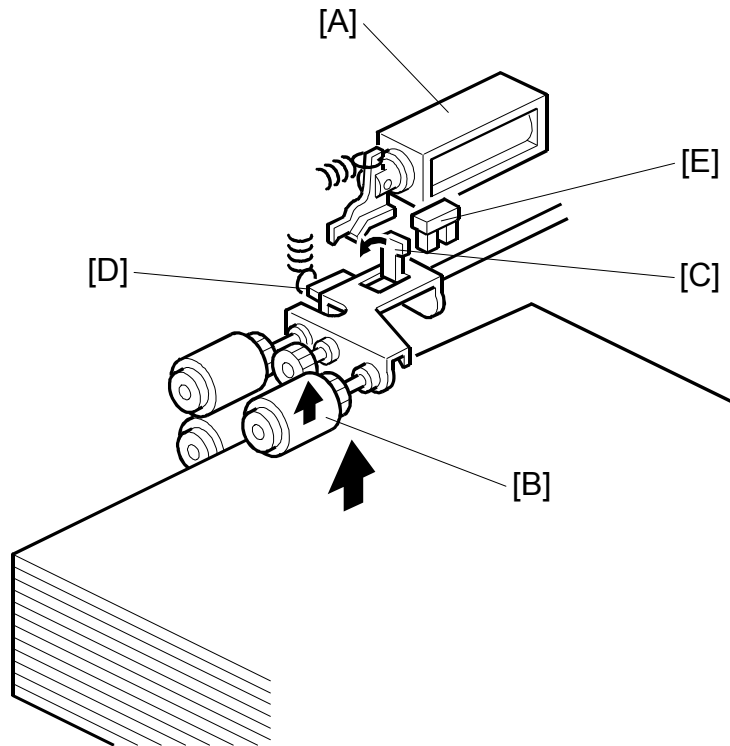

B511D108.WMF

When the lift motor turns on, the pick-up solenoid [A] activates to lower the pick-up roller [B]. When the top sheet of paper reaches the proper paper feed level, the paper pushes up the pick-up roller and the actuator [C] on the pick-up roller supporter [D] de-activates the lift sensor [E] to stop the lift motor.

After several paper feeds, the paper level gradually lowers, then the lift sensor is activated and the lift motor turns on again until the lift sensor is de-activated again.

6.4 PAPER SIZE DETECTION

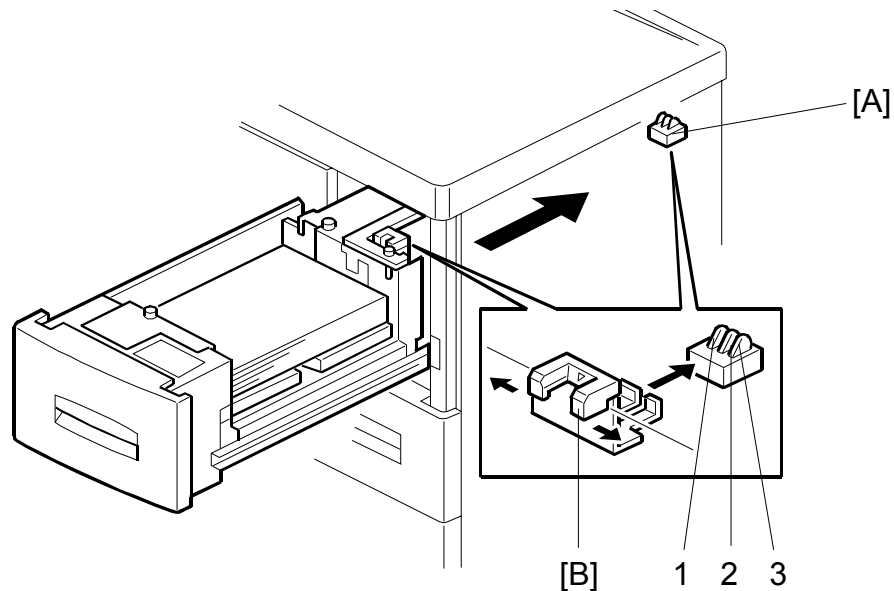

B511D111.WMF

	A4-LEF	B5-LEF	A5-LEF	A5-SEF	LT-LEF	HLT-LEF	HTL-SEF
SW1	0	1	0	0	0	1	1
SW2	1	0	1	0	0	0	1
SW3	1	1	0	1	0	0	0

1: HI 0: LOW

Top Tray (Tray 1) and Middle Tray (Tray 2)

For the top and middle trays, the paper size switch [A] detects the paper size. The paper size switch contains three microswitches. The paper size switch is actuated by an actuator plate [B] at the rear of the tray. Each paper size has its own unique combination as shown in the table and the CPU determines the paper size by the combination.

Bottom Tray (Tray 3)

The bottom tray has the same switch as the top and middle trays. However, it is only used for detecting when the tray is pushed in.

For the bottom tray, the paper size must be selected in the SP5019-007:

6.5 REMAINING PAPER DETECTION

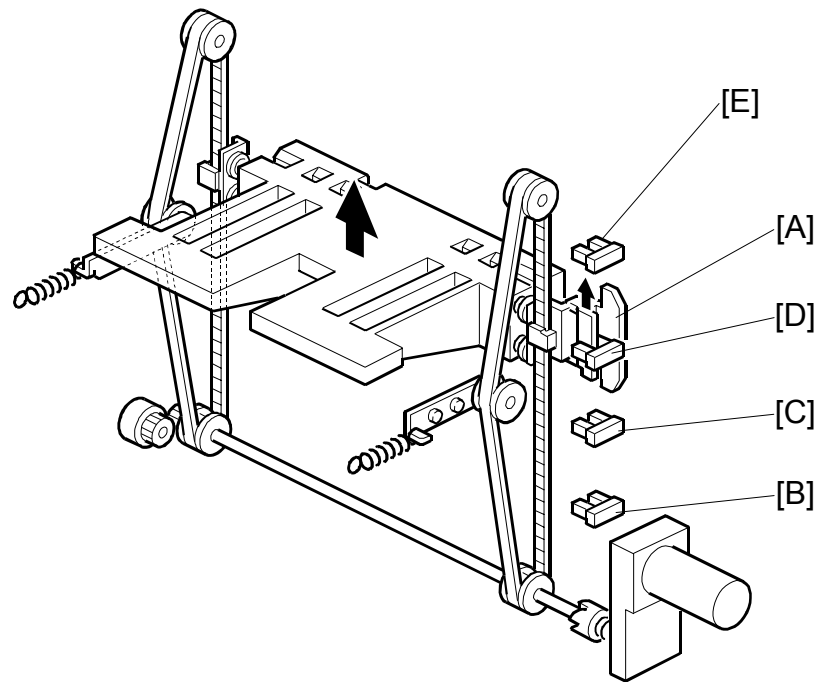

B511D109.WMF

The amount of paper remaining in the tray is detected by the three paper height photointerrupter sensors on the left rail as the bottom plate rises. Five states, determined by the position of the actuator are possible.

1. With the actuator [A] below paper height sensor 1 [B], no sensor is actuated and the display indicates 100%.
2. When the actuator passes paper height sensor 1 [B], the display indicates 75% of the paper supply remaining.
3. When the actuator passes paper height sensor 2 [C], the display indicates 50% of the paper supply remaining.
4. When the actuator passes paper height sensor 3 [D], the display indicates 25% of the paper supply remaining.

NOTE: When the actuator enters the gap of the near end sensor [E], the machine signals near end.

Finally, when the last sheet feeds, the paper end sensor signals that the tray is empty. (➡6.6)

6.6 PAPER END DETECTION

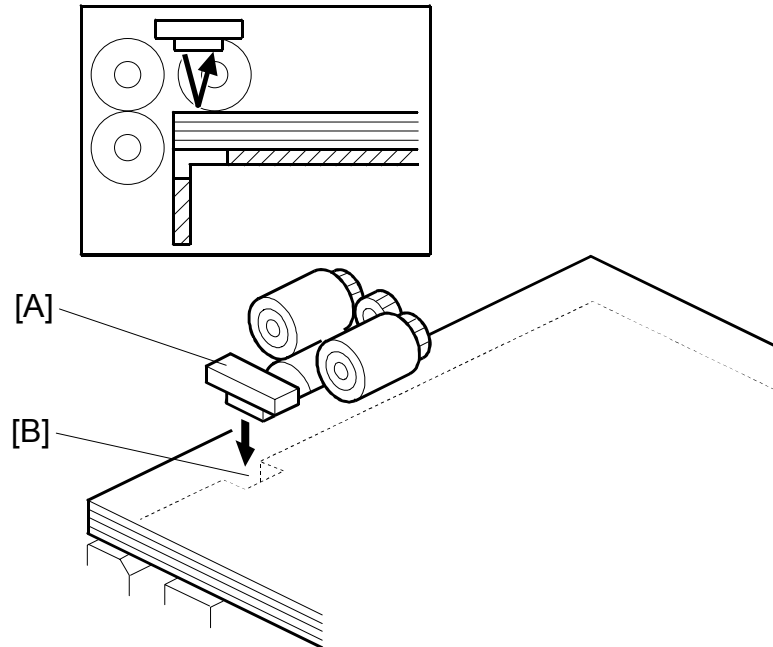

B511D110.WMF

The paper end sensor [A] detects the top sheet of the paper in the tray by monitoring the reflected light. When the paper tray runs out of paper, the paper end sensor does not receive the reflected light due to the cutout [B]. Then, the tray lift motor rotates backwards 2 seconds to drop the tray bottom plate.

7. OVERALL MECHANICAL INFORMATION

7.1 MECHANICAL COMPONENT LAYOUT

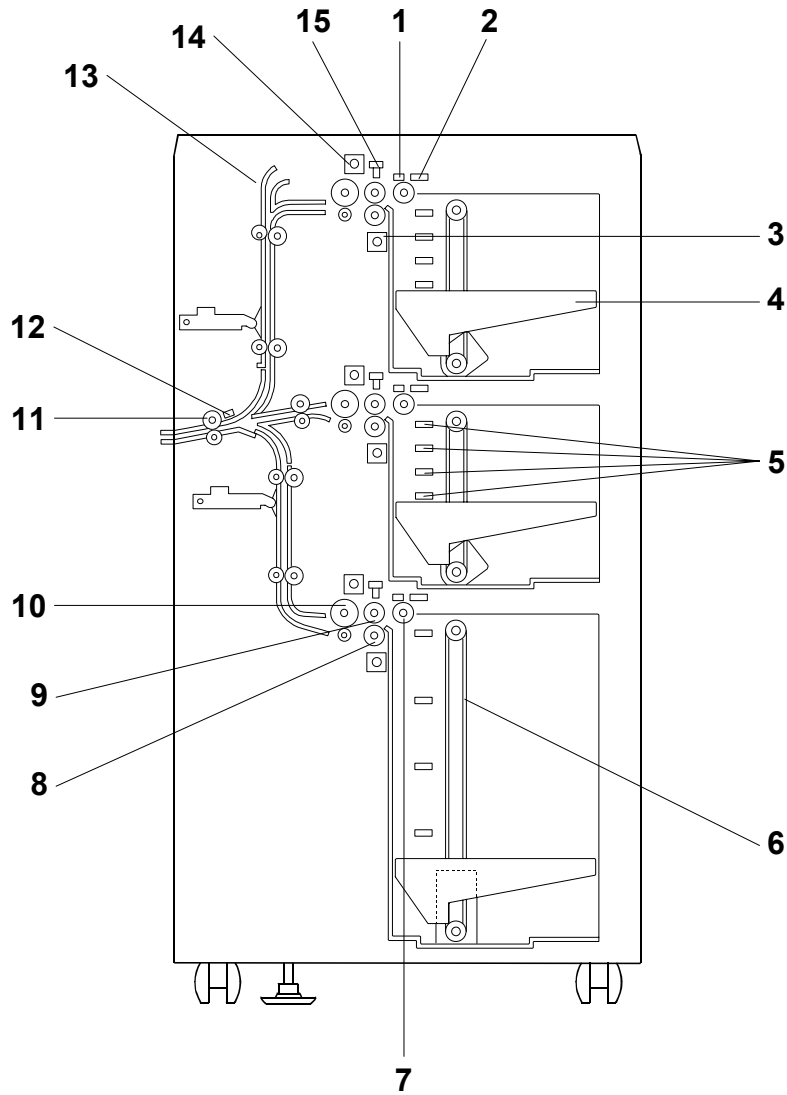

B511V101.WMF

- | | |
|-------------------------|------------------------------------|
| 1. Paper Feed Sensor | 9. Paper Feed Roller |
| 2. Paper End Sensor | 10. Grip Roller |
| 3. Separation Solenoid | 11. Relay Roller |
| 4. Paper Tray | 12. Relay Sensor |
| 5. Paper Height Sensors | 13. <u>Feed Slot (Bypass Tray)</u> |
| 6. Tray Drive Belt | 14. Pick-up Solenoid |
| 7. Pick-up Roller | 15. Lift Sensor |
| 8. Separation Roller | |

7.2 ELECTRICAL COMPONENT DESCRIPTIONS

Symbol	Name	Function
Clutches		
MC1	Transport	Drives the transport rollers in the LCT.
MC2	1st Paper Feed	Drives the paper feed roller in the 1st tray.
MC3	1st Grip	Drives the grip roller in the 1st tray.
MC4	2nd Paper Feed	Drives the paper feed roller in the 2nd tray.
MC5	2nd Grip	Drives the grip roller in the 2nd tray.
MC6	3rd Paper Feed	Drives the paper feed roller in the 3rd tray.
MC7	3rd Grip	Drives the grip roller in the 3rd tray
Motors		
M1	LCT	Drives all rollers in the LCT.
M2	1st Lift	Drives the 1st tray up and down.
M3	2nd Lift	Drives the 2nd tray up and down.
M4	3rd Lift	Drives the 3rd tray up and down.
PCB		
PCB1	LCT Control Board	Controls the LCT and communicates with the copier.
Sensors		
SN1	1st Paper Height 1	Detects the paper height in the 1st tray.
SN2	1st Paper Height 2	Detects the paper height in the 1st tray.
SN3	1st Paper Height 3	Detects the paper height in the 1st tray.
SN4	1st Paper Height 4	Detects the paper height in the 1st tray.
SN5	2nd Paper Height 1	Detects the paper height in the 2nd tray.
SN6	2nd Paper Height 2	Detects the paper height in the 2nd tray.
SN7	2nd Paper Height 3	Detects the paper height in the 2nd tray.
SN8	2nd Paper Height 4	Detects the paper height in the 2nd tray.
SN9	3rd Paper Height 1	Detects the paper height in the 3rd tray.
SN10	3rd Paper Height 2	Detects the paper height in the 3rd tray.
SN11	3rd Paper Height 3	Detects the paper height in the 3rd tray.
SN12	3rd Paper Height 4	Detects the paper height in the 3rd tray.
SN13	Exit	Checks for the presence of paper (misfeeds) at the LCT exit.
SN14	1st Paper Feed	Detects the copy paper coming to the 1st paper feed roller and checks for misfeeds.
SN15	1st Paper End	Informs the copier when the paper in the 1st tray has run out.
SN16	1st Lift	Detects when the paper in the 1st tray is at the correct paper feed height.
SN17	2nd Paper Feed	Detects the copy paper coming to the 2nd paper feed roller and checks for misfeeds.
SN18	2nd Paper End	Informs the copier when the paper in the 2nd tray has run out.
SN19	2nd Lift	Detects when the paper in the 2nd tray is at the correct paper feed height.
SN20	3rd Paper Feed	Detects the copy paper coming to the 3rd paper feed roller and checks for misfeeds.
SN21	3rd Paper End	Informs the copier when the paper in the 3rd tray has run out.

Symbol	Name	Function
SN22	3rd Lift	Detects when the paper in the 3rd tray is at the correct paper feed height.
Solenoids		
SOL1	1st Separation	Controls up-down movement of the separation roller in the 1st tray.
SOL2	2nd Separation	Controls up-down movement of the separation roller in the 2nd tray.
SOL3	3rd Separation	Controls up-down movement of the separation roller in the 3rd tray.
SOL4	1st Pick-up	Controls up-down movement of the pick-up roller in the 1st tray.
SOL5	2nd Pick-up	Controls up-down movement of the pick-up roller in the 2nd tray.
SOL6	3rd Pick-up	Controls up-down movement of the pick-up roller in the 3rd tray.
Switches		
SW1	Front Door Safety	Detects whether the tray cover is opened or not.
SW2	1st Paper Size	Detects the paper size in the 1st tray, and whether the 1st tray is in the machine.
SW3	2nd Paper Size	Detects the paper size in the 2nd tray, and whether the 2nd tray is in the machine.
SW4	3rd Paper Size	Detects whether the 3rd tray is in the machine. The paper size must be input with a user tool.

7.3 DRIVE LAYOUT

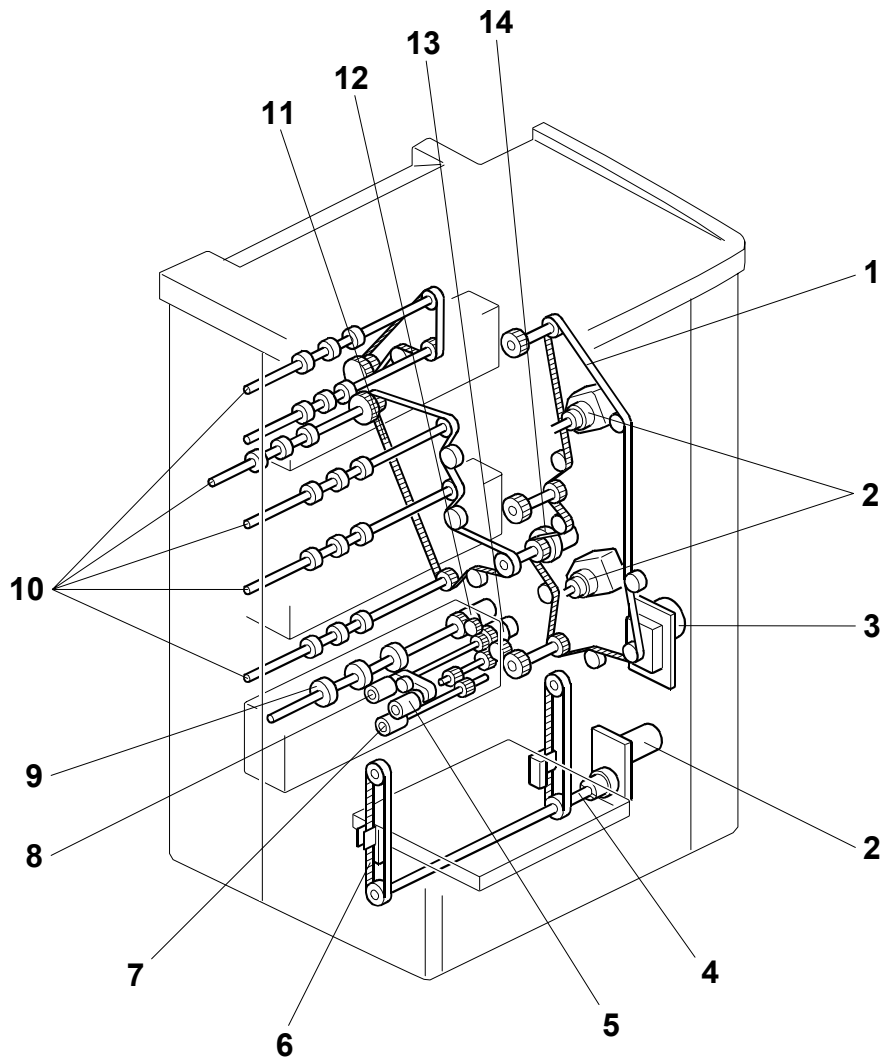

B511V102.WMF

- | | |
|----------------------|---------------------------------|
| 1. Main Drive Belt | 8. Paper Feed Roller |
| 2. Tray Lift Motors | 9. Grip Roller |
| 3. LCT Motor | 10. Transport Rollers |
| 4. Tray Drive Shaft | 11. Transport Roller Drive Belt |
| 5. Pick-up Roller | 12. Grip Roller Clutch |
| 6. Tray Drive Belt | 13. Paper Feed Clutch |
| 7. Separation Roller | 14. Transport Clutch |

Peripherals